

ASSEMBLY INSTRUCTION

ITEM: EC846-088 Lenora Swivel Tilt Executive Chair

Thank you for purchasing this quality product. Be sure to unpack carefully looking for small parts which may have come loose during shipment.

Read all instruction and study the drawing carefully before starting the assembly process.



1. Please sit down onto the chair and use the left handle (A) to adjust the reclining of the chair, and use the right handle (B) to adjust the height of it.
2. Pull the left handle (A) out and the chair is active to recline. Get a desired tilt and release the left handle to lock it. You can lock at several different tilt angles by reclining your body.
3. Turn the right handle (B) upward to activate the cylinder for adjusting the height of the chair. Raise your body up, the seat will be lifted up to a desired height by the cylinder. To get a lower height, please sit down with the right handle (B) turning upward. Release the right handle (B) to lock the cylinder when you achieve a desired seat height.
4. Turn the knob (C) clockwise to lessen the tension and counter clockwise to tighten the tension.

Parts As Shown

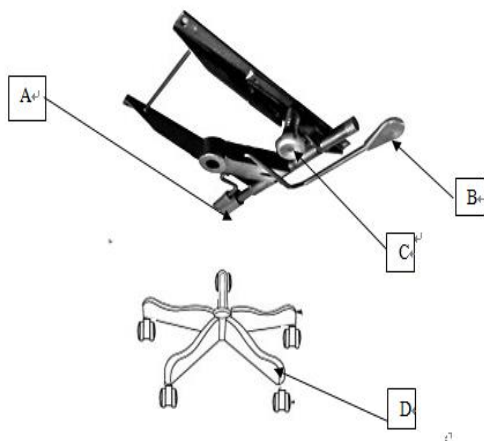

- A. Left handle--for reclining
- B. Right handle—for adjusting seat height
- C. Tilt tension knob
- D. Base set

ASSEMBLY INSTRUCTION

ITEM: EC846-088 Lenora Swivel Tilt Executive Chair

Thank you for purchasing this quality product. Be sure to unpack carefully looking for small parts which may have come loose during shipment.

Read all instruction and study the drawing carefully before starting the assembly process.



Carefully unpack all parts and identify them with parts list before attempting to assemble the chair.

IMPORTANT: DO NOT TIGHTEN BOLTS AND SCREWS FULLY UNTIL YOU HAVE COMPLETED THE FINAL ASSEMBLY.

1. Carefully remove the 5 STAR BASE (B) from the carton.
The base is located behind the fiberboard that is behind the chair UNIT SEATING(G).
2. Put 5 CASTERS (A) into the holes of 5 STAR BASE (B).
3. Insert GAS LIFT (C) to the center hole top of 5 STAR BASE (B), and put the BELLOWS (D) onto the GAS LIFT(C).
4. Attach SEAT PLATE (F) to the Unit Seating (G) by using 4 SCREWS (E) with 4 FLAT WASHERS (E1).
5. Insert the pre-assembled seat unit onto the gas lift to finish the final assembly.
6. Be sure that all the screws are fully tightened before using.

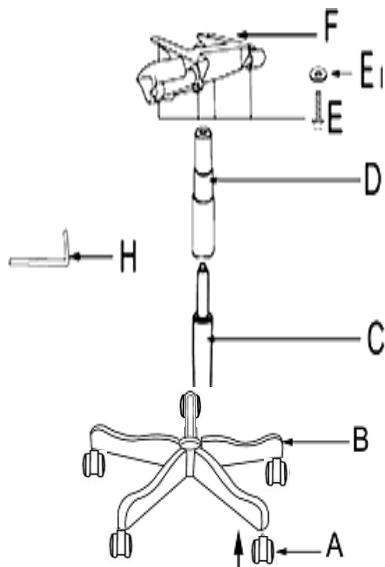

Parts List

A. CASTERS	5
B. 5 STAR BASE	1
C. GAS LIFT	1
D. BELLOWS (only available on wood cap base, not available on metal base)	1
E. SCREWS (5/16"x1-1/4")	4
E1. FLAT WASHERS	4
F. SEAT PLATE	1
G. UNIT SEATING	1
H. ALLEN KEY	1