

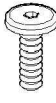

ASSEMBLY INSTRUCTION

PARTS & HARDWARE

No.	Description	Qty	No.	Description	Qty
A	 Top	1	D	 Allen Bolt	9
B	 B1,B2,B3 Legs	3	E	 Allen Key	1
C	 Leg Support	1			

STEP 1. Keep the top on soft surface as keep below and base

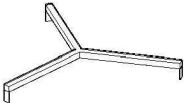
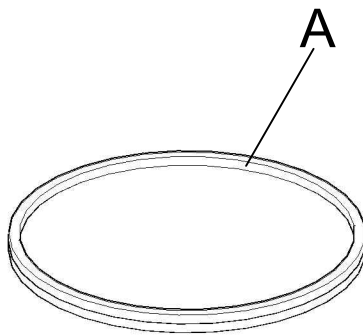

STEP 2. Please Align the Legs with Top holes for fixing with Bolt and Do Not complete tightened the Bolt.

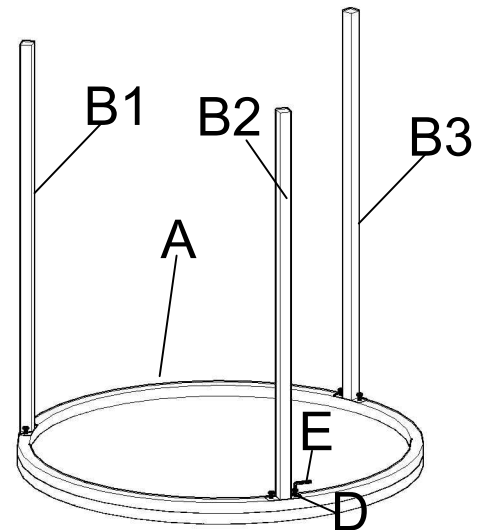

STEP 3. Please align the Leg support with Legs for fixing with Bolt and tightened the all Bolt.

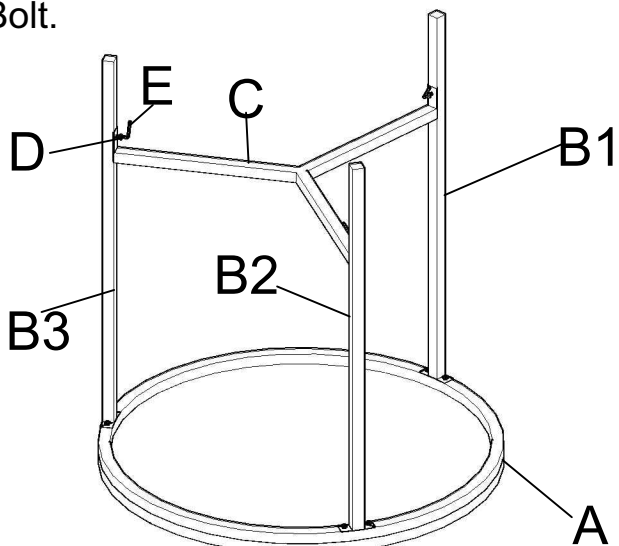

STEP 4. Complete Product

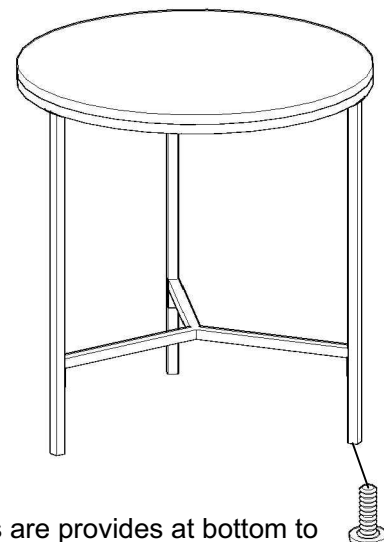

Note. Levellers are provides at bottom to balance the product on uneven surface