





ASSEMBLY INSTRUCTIONS





ACCENT CHAIR

CVFDR1175

PARTS

S.NO.	DESCRIPTION	QNT
A	 CHAIR BACK	01
B	 CHAIR SEAT	01
C	 RIGHT LEG	01
D	 LEFT LEG	01

HARDWARE

S.NO.	DESCRIPTION	QNT
E	 WASHER	11
F	 SPRING WASHER	11
G	 JCBC M6 x 40	11
H	 ALLEN KEY	01

STEP - 1

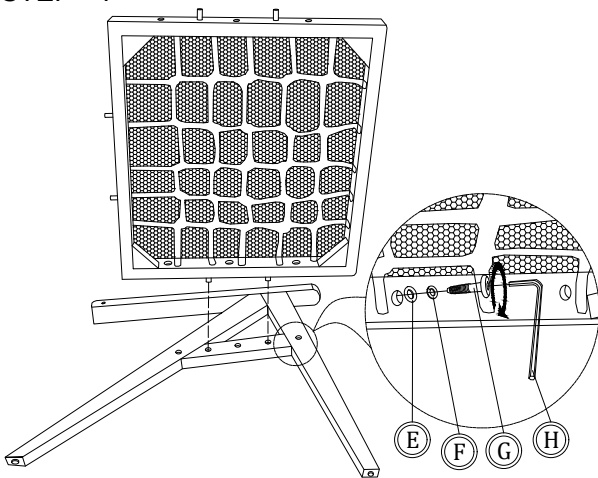

Place the left legs (D) on the floor, then install the chair seat (B), then fasten it by installing the Washer (E), Spring washer (F) JCBC M6x40 (G) and gently tighten with the allen key (H) Do not screw it too tight

STEP - 2

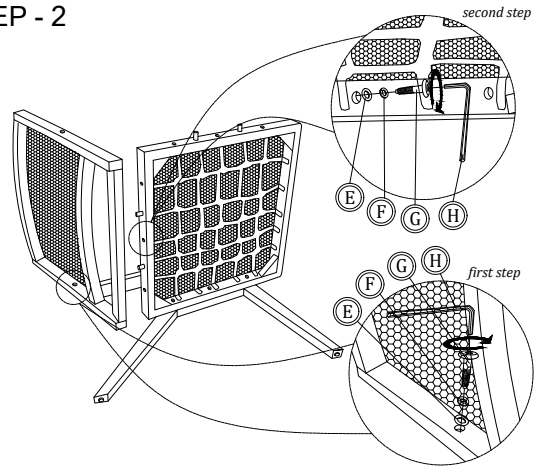

Install the chair back part (A), following the picture above, then install the Washer (E), Spring washer (F), JCBC M6x40 (G), then gently tighten it with the allen key (H) Do not screw it too tight

STEP - 3

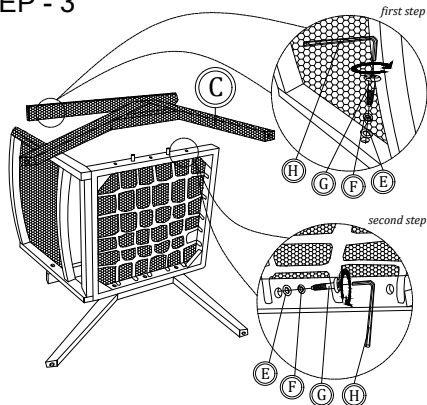

Install the right legs on the previous body, then install the Washer (E), Spring washer (F) JCBC M6x40 (G) then gently tighten it with the allen key (H) Do not screw it too tight

COMPLETED

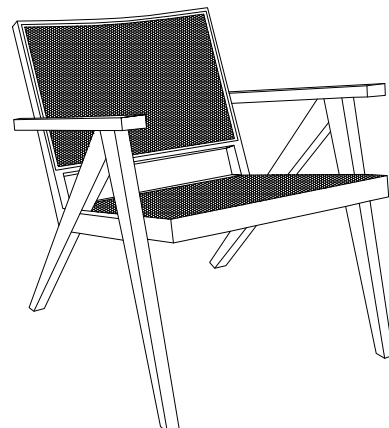

Now turn the chair up to right side. If the bottom is not stable enough, please adjust the legs to make it stable, at last, you can tighten all bolts.

MADE IN INDONESIA