

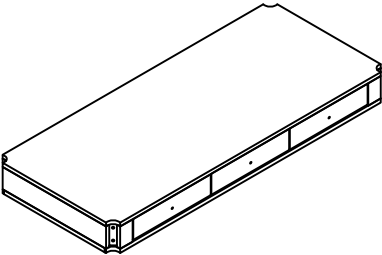









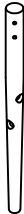



CVFVR8616-ASSEMBLY INSTRUCTIONS

PARTS LIST

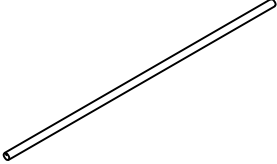
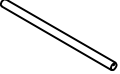
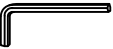
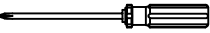
NO	HARDWARE LIST		Q'TY	A x 1 Table Top	B1 (L) x 1 Rear Left Leg	B2 (R) x 1 Rear Right Leg	B3 (L) x 1 Front Left Leg
①		Bolt (5/16"x60mm)	8				
②		Spring Washer (Ø5/16")	8				
③		Flat Washer (5/16" x 16mm)	8				
④		Wood Screw (#4 x 45mm)	6				
⑤		Phillips Screw (5/32" x 30mm)	3	B4 (R) x 1 Front Right Leg	F x 1 Long Stretcher	G x 2 Short Stretcher	
⑥		Knob	3				
⑦		Allen Key (M4)	1				
		NOT SUPPLIED					



CVFVR8616-ASSEMBLY INSTRUCTIONS

STEP: 1

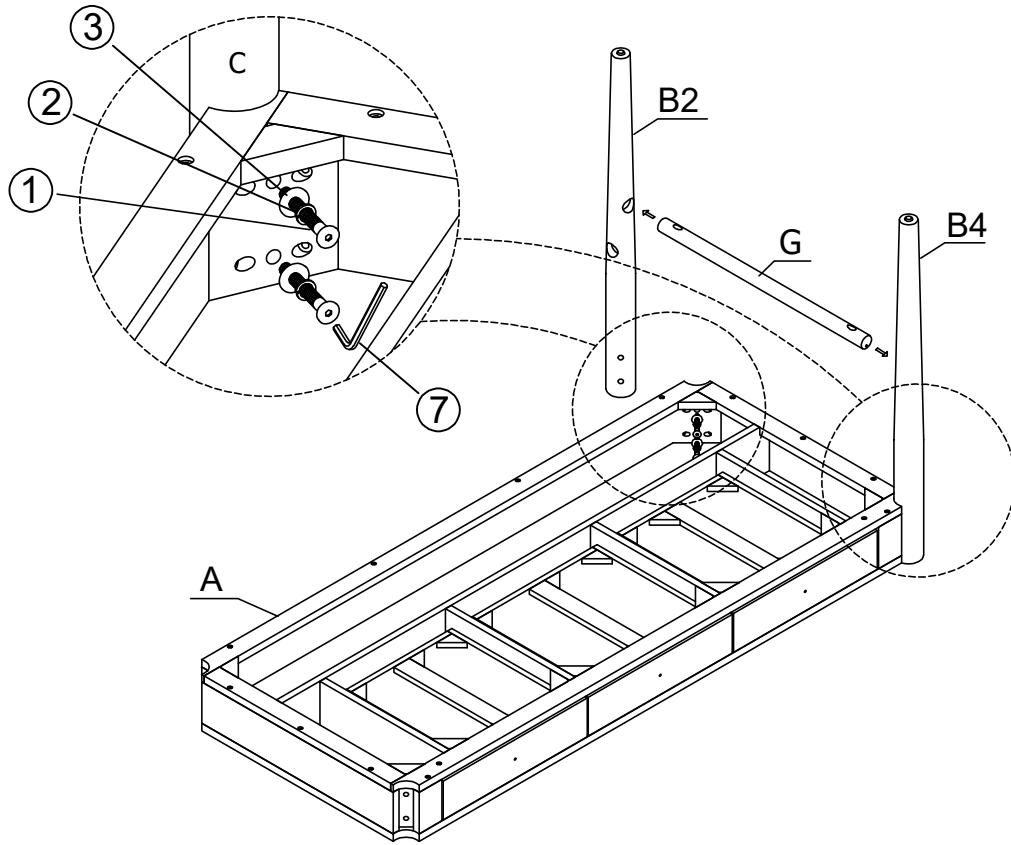
1	2	3
		
04PCS	04PCS	04PCS



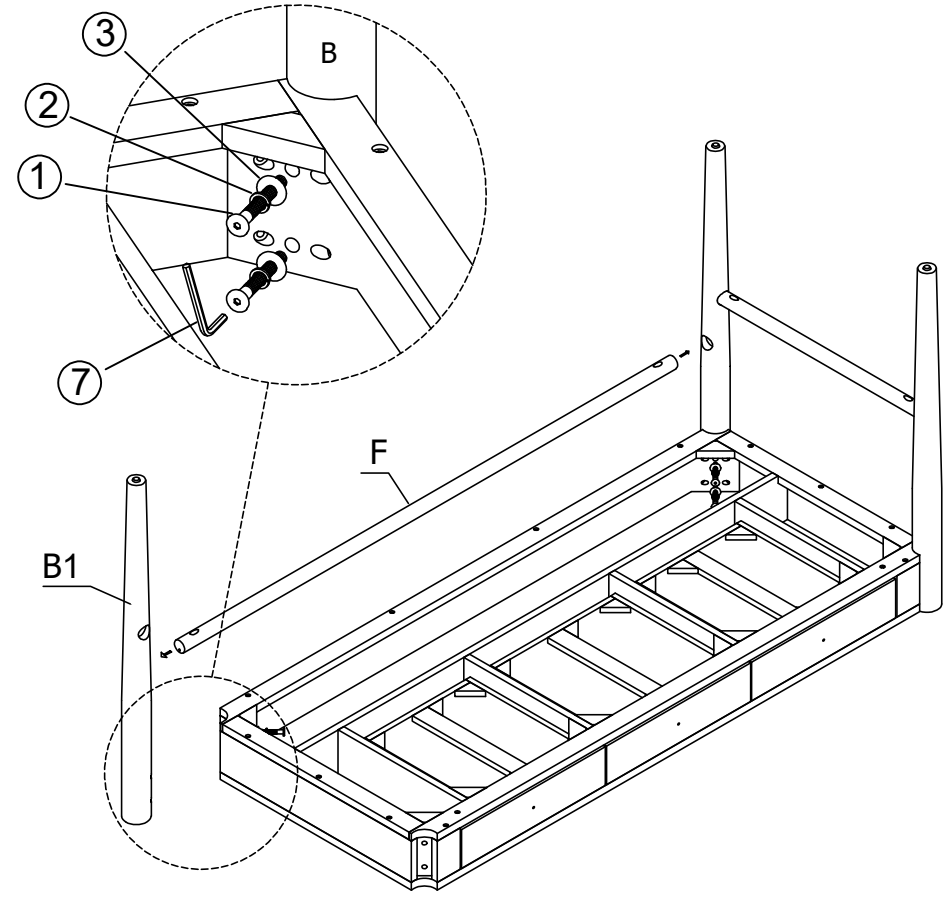

STEP: 2

1	2	3
		
02PCS	02PCS	02PCS



CVFVR8616-ASSEMBLY INSTRUCTIONS

STEP: 3

1	2	3
		
02PCS	02PCS	02PCS

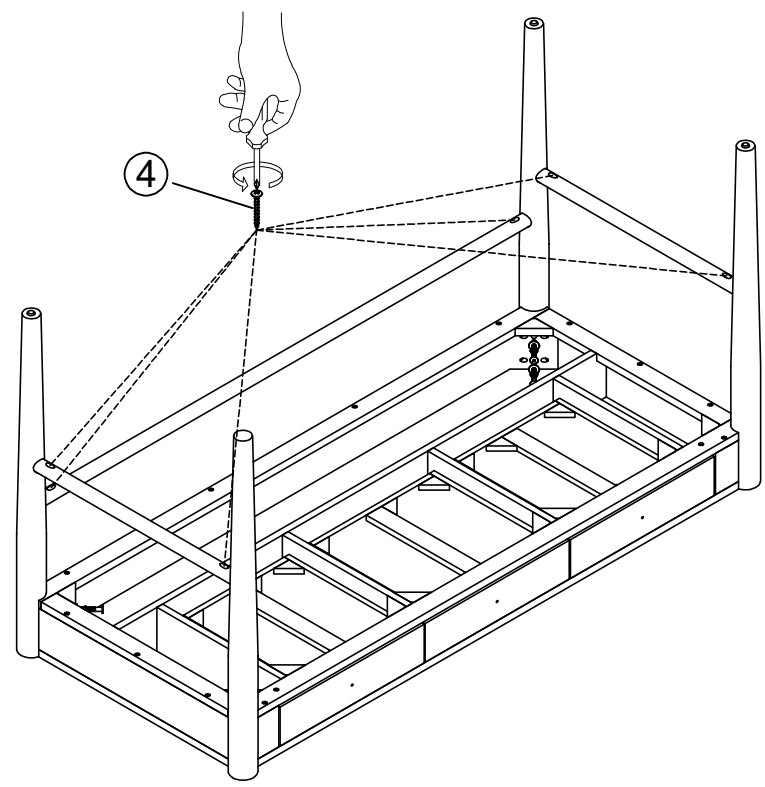
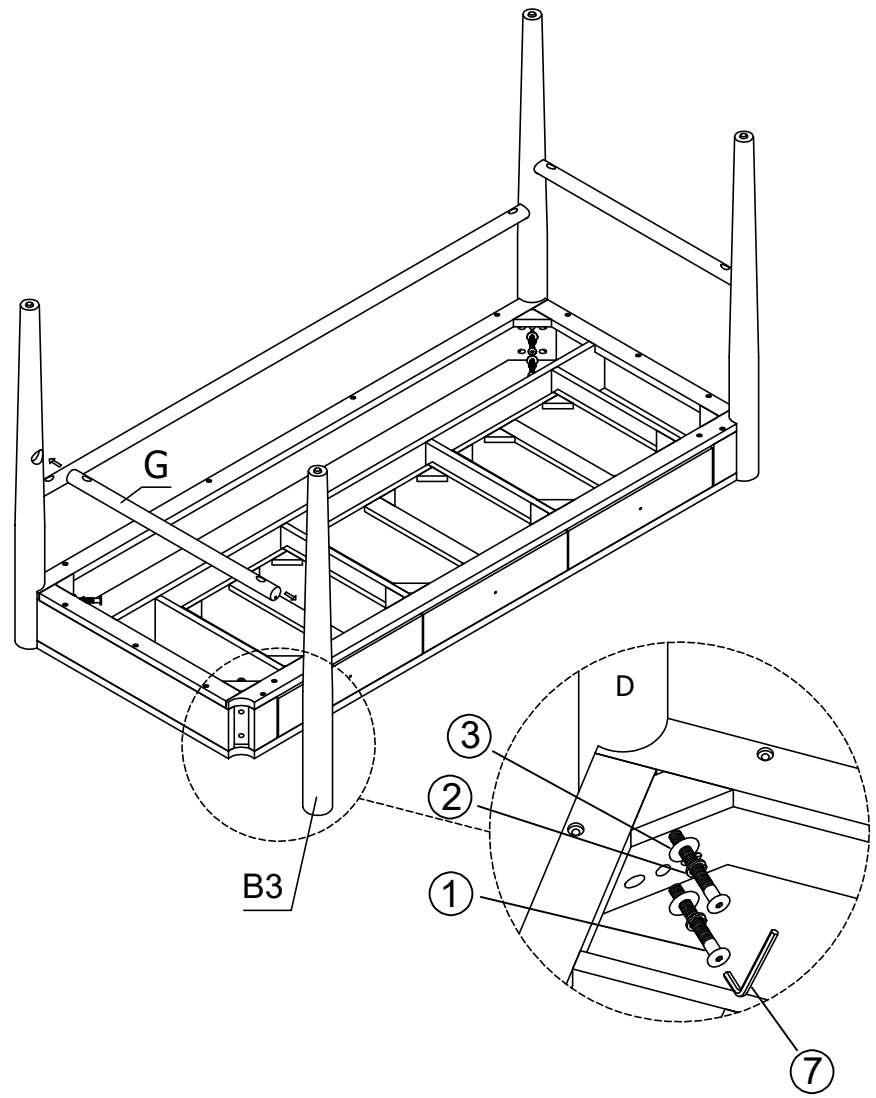

STEP: 4

4

06PCS



CVFVR8616-ASSEMBLY INSTRUCTIONS

STEP: 5

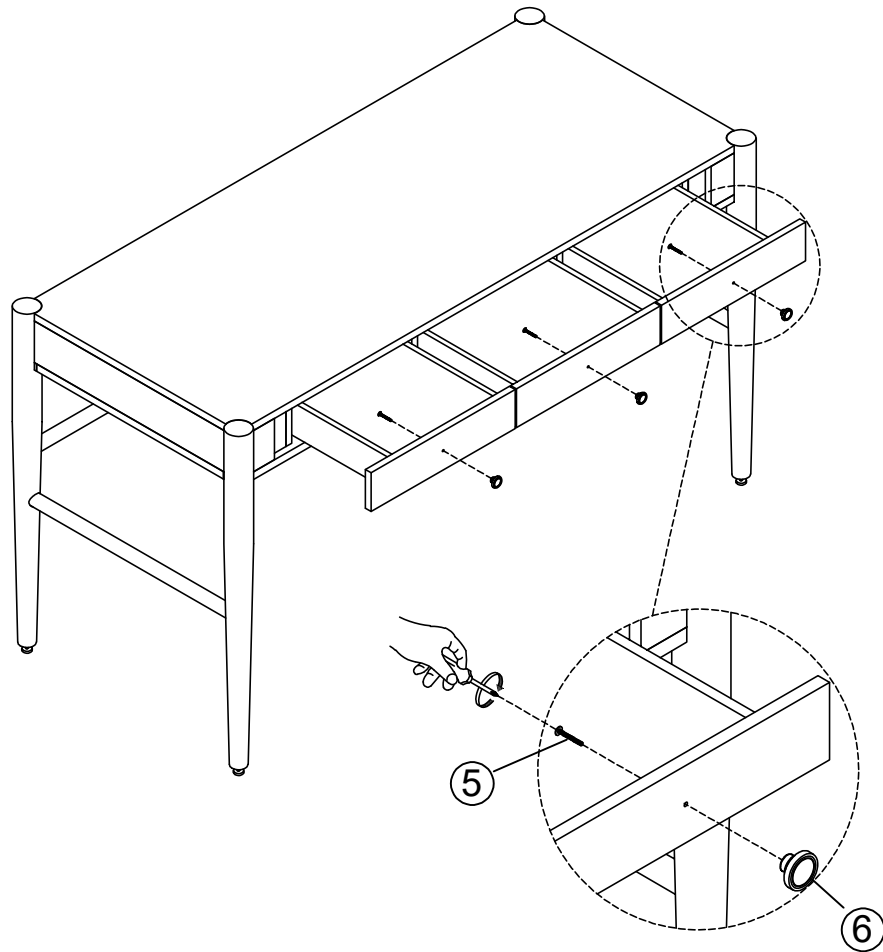
5	6
	
03PCS	03PCS



FINISH

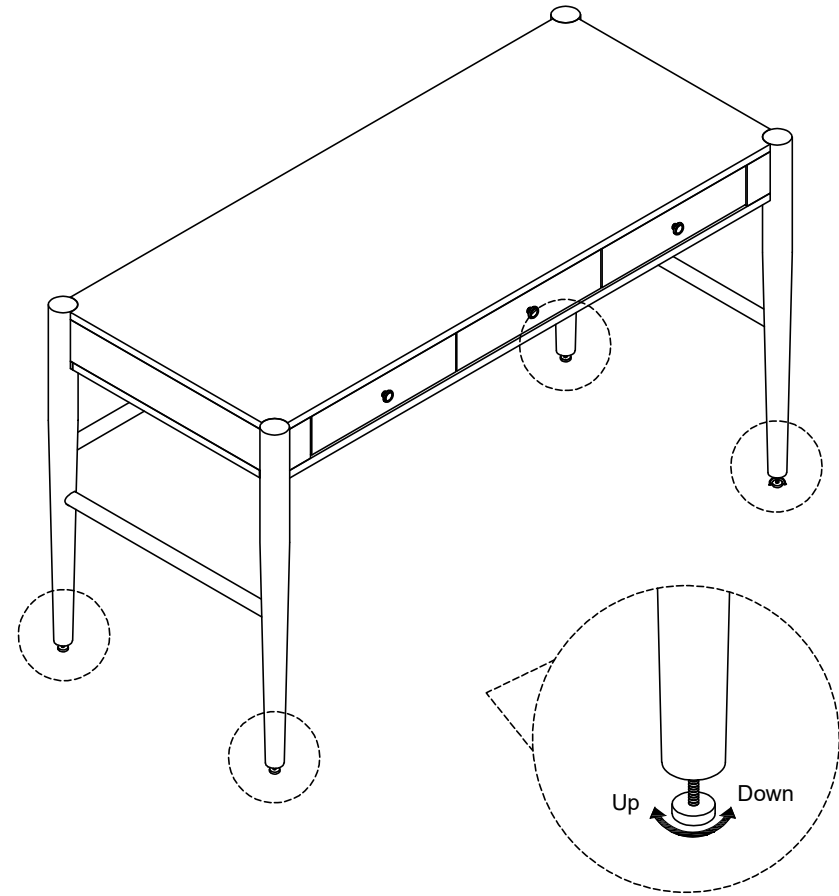

Leveler can be adjusted as necessary for the dresser balance