









ASSEMBLY INSTRUCTIONS

CVFNR4527

PARTS

S.NO.	DESCRIPTION	QTY.
A	 BASE	1 PC
B	 LEG FRAME B1, B2	2 PCS
C	 SQUARE LEG FRAME C1, C2, C3, C4	1 PC
D	 Drawer	1 PC

HARDWARE

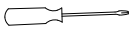
S.NO.	DESCRIPTION	QTY.
E	 WASHER 20x6 mm	6 PCS
F	 NUT 35x5 mm	6 PCS
G	 NUT 25x5 mm	4 PCS
H	 SPANNER 10-11 No.	1 PC
I	 SCREW DRIVER	1 PC

STEP-1

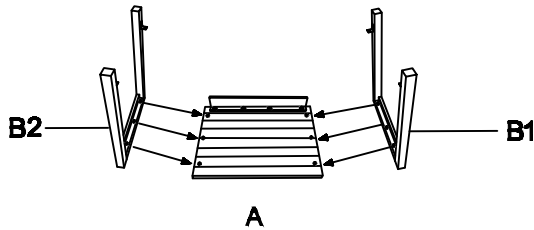

STEP-2

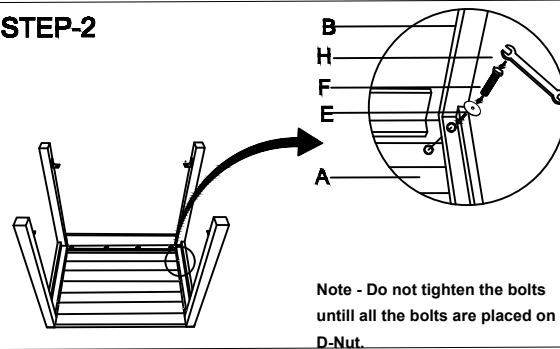

Note - Do not tighten the bolts until all the bolts are placed on D-Nut.

STEP-3

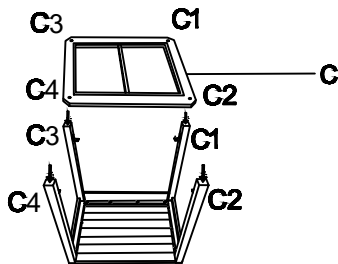

STEP-4

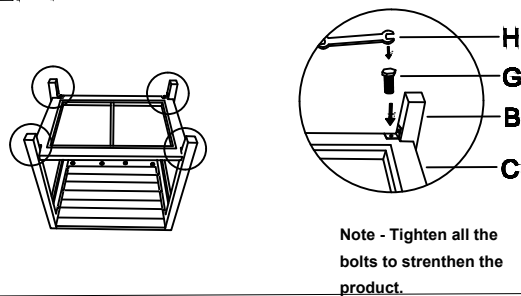

Note - Tighten all the bolts to strengthen the product.

STEP-5

Note - Knob is reversly installed inside the drawer. Use screw driver to open and install in the front of drawer.

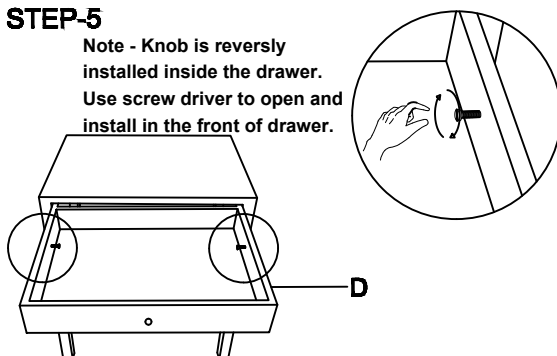

Note : Tighten the bolts for stopping the drawer movement.

STEP-6

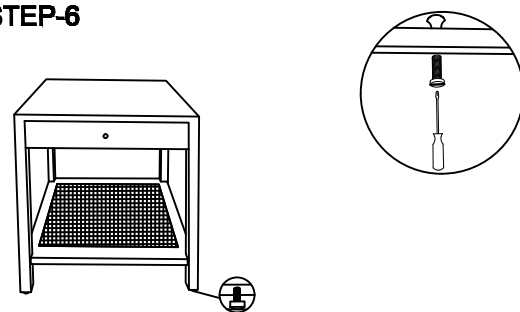

Note : Levelers are provided at bottom to balance the product on uneven surfaces.